

Production of High Quality Dry Ice Pellets

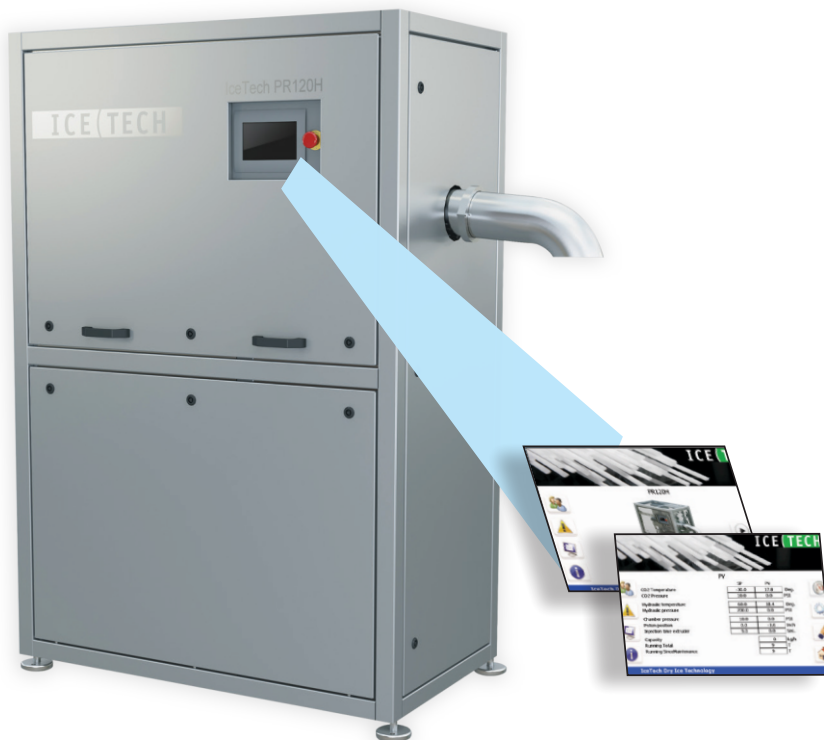

The fully automatic PR120H is an efficient pelletizer designed to produce consistent, high quality dry ice pellets using liquid CO₂ and electrical power. The PR120H is differentiated by its reduced cost and high quality output. With minimal space requirements and no need to have a built-in liquid CO₂ tank, the PR120H can produce up to 120kg/265lbs of dry ice pellets per hour. Producing dry ice on demand has never been easier!

Unique Features:

- Stainless steel enclosure reduces noise level below 75 db(A) and protects machine components
- Fully automated, one-button operation
- Panel PC with built-in 7" touch screen
- Heat exchanger minimizes CO₂ waste
- Quick startup reduces downtime and loss of valuable CO₂
- No need for a fixed CO₂ tank (less infrastructure costs)
- Compact footprint
- Free choice of die plates:
mm: 3, 9, 16
inch: 1/8, 3/8, 5/8

Benefits of Dry Ice Production:

- Produce fresh, high density dry ice on demand
- Reduce wasted dry ice due to sublimation
- Eliminate transportation costs
- Low ownership and maintenance costs

PR120H

Production of High Quality Dry Ice Pellets

PR120H Technical Data

Rated Output:

kg/h: up to 120 kg/h
lbs/h: up to 265 lbs/h
of high quality dry ice pellets

Pellet Diameter Range:

mm : 3, 9, 16
inch: 1/8, 3/8, 5/8
custom die plate design program available

Dimensions mm/inch:

Length: 1150/45.3
Width: 650/25.6
Height: 1738/68.4

Weight:

kg: 754/ lbs: 1662

Inlet CO₂ Supply:

bar: 16 - 22
psi: 232 - 319

Compressed air or vapor CO₂ gas supply:

bar: 8 - 10
psi: 116 - 145

Air quality:

Class 3 - according to ISO 8573-1

Back Pressure on Revert Gas:

bar: 0 - 1
psi: 0 - 14.5

Exhaust Gas Pipe:

Internal dia. 50 mm (2 inch)

Power Supply:

3 x 400 V AC + N + PE, 50Hz
TN-S Earthing system
Imax.: 16A
Ipk: 10 kA
480V AC Solidly Grounded Wye Source
3 Phase + GND wire, 60Hz
Imax.: 16A
Control Panel SCCR: 25kA rms symmetrical
480VAC Max.

Rated Power:

8.3 kW

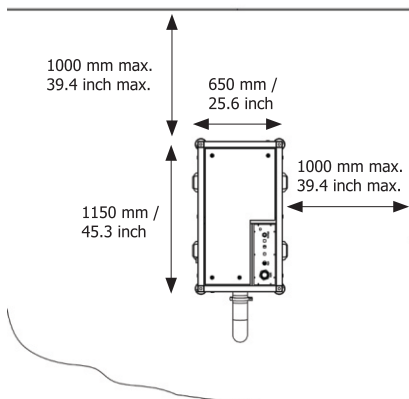
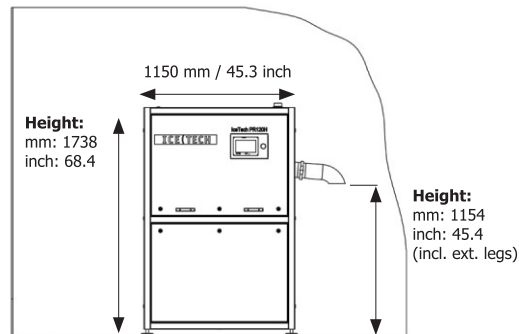
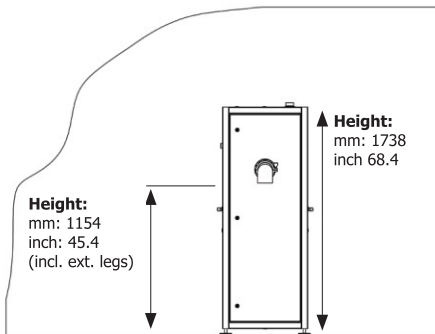
Noise Level: below 75 db(A)**Floor Characteristics and Minimum Clearance Distances**

The pelletizer must be placed on a horizontal concrete floor with an adequate load-carrying capacity. The floor must be free of cracks and structural deficiencies. The minimum clearance distances must be observed to provide sufficient space for opening the cabinet doors and servicing the pelletizer.

Installation

The installation of the pelletizer must be carried out by one of Cold Jet's service technicians or by a technician approved by Cold Jet.